

SherpaLoader®

Camera-guided CNC automation
for small and medium-sized batches

THE ALL-ROUNDER

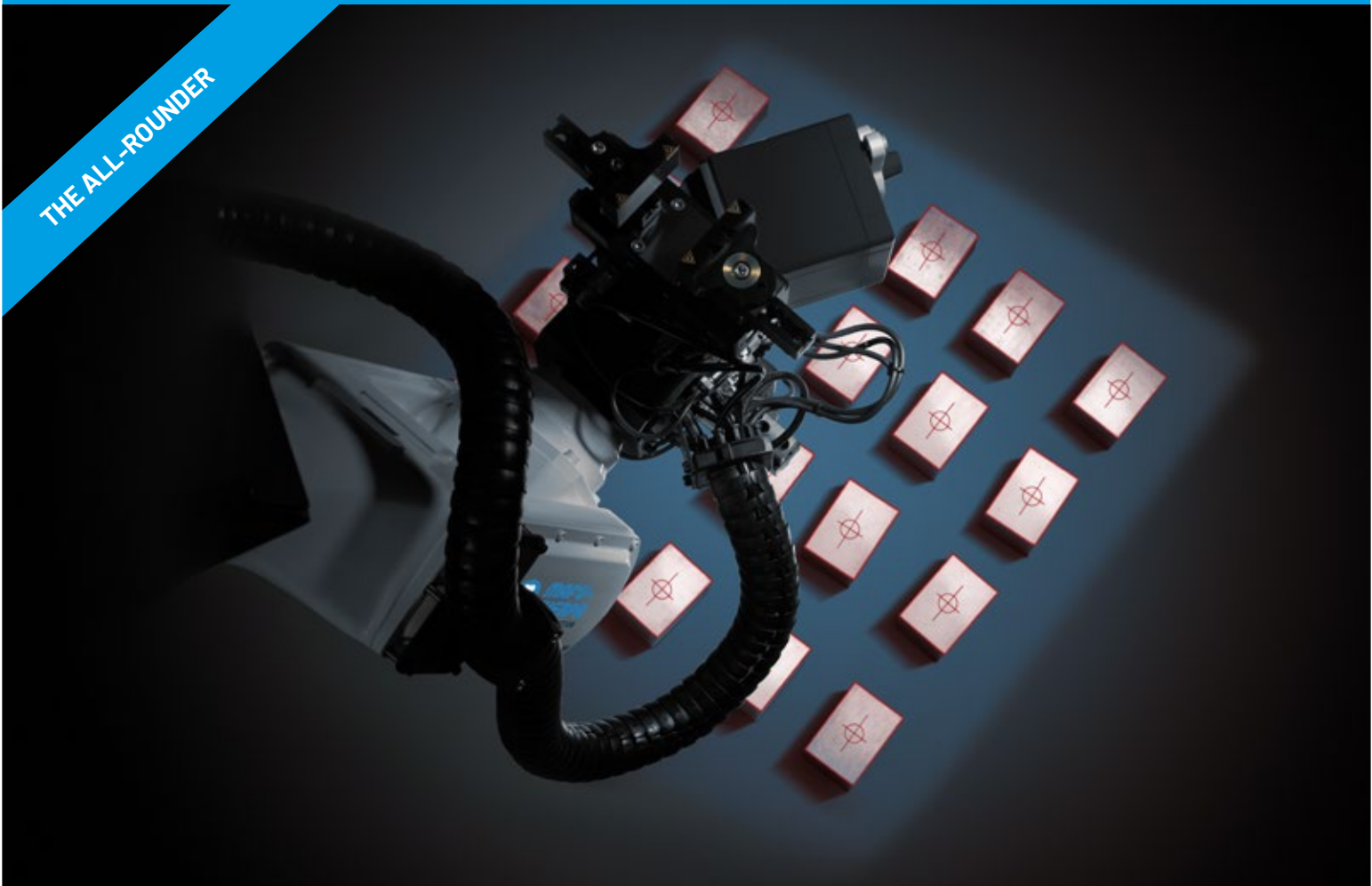

Challenges for SME Contract Manufacturers

Decreasing
Batch Sizes often 20-500 parts

Increasing
Production Cost

Fluctuating
Order Intake

Shorter **Delivery Periods**
at no extra margin

Lack of
Skilled Operators

Price Pressure
from low-cost countries

The solution: a camera-laser-dual-gripper-six-axis-robot, or simply:

The SherpaLoader®



Camera-guided

SherpaLoaders®
see what they load



Intuitive

Robot control made
simple: Zero coding



Flexible

For today, tomorrow,
and whatever comes next



Camera-guided

At the heart of the system: SherpaVision® – the advanced camera-laser solution that detects workpieces without grid plates. It eliminates the hassle of constant retooling, error-prone magazine programming, and the high costs of automated rotary or stacking tables. A protective cover shields the lens, ensuring a clear view and reliable performance even in tough operating conditions.

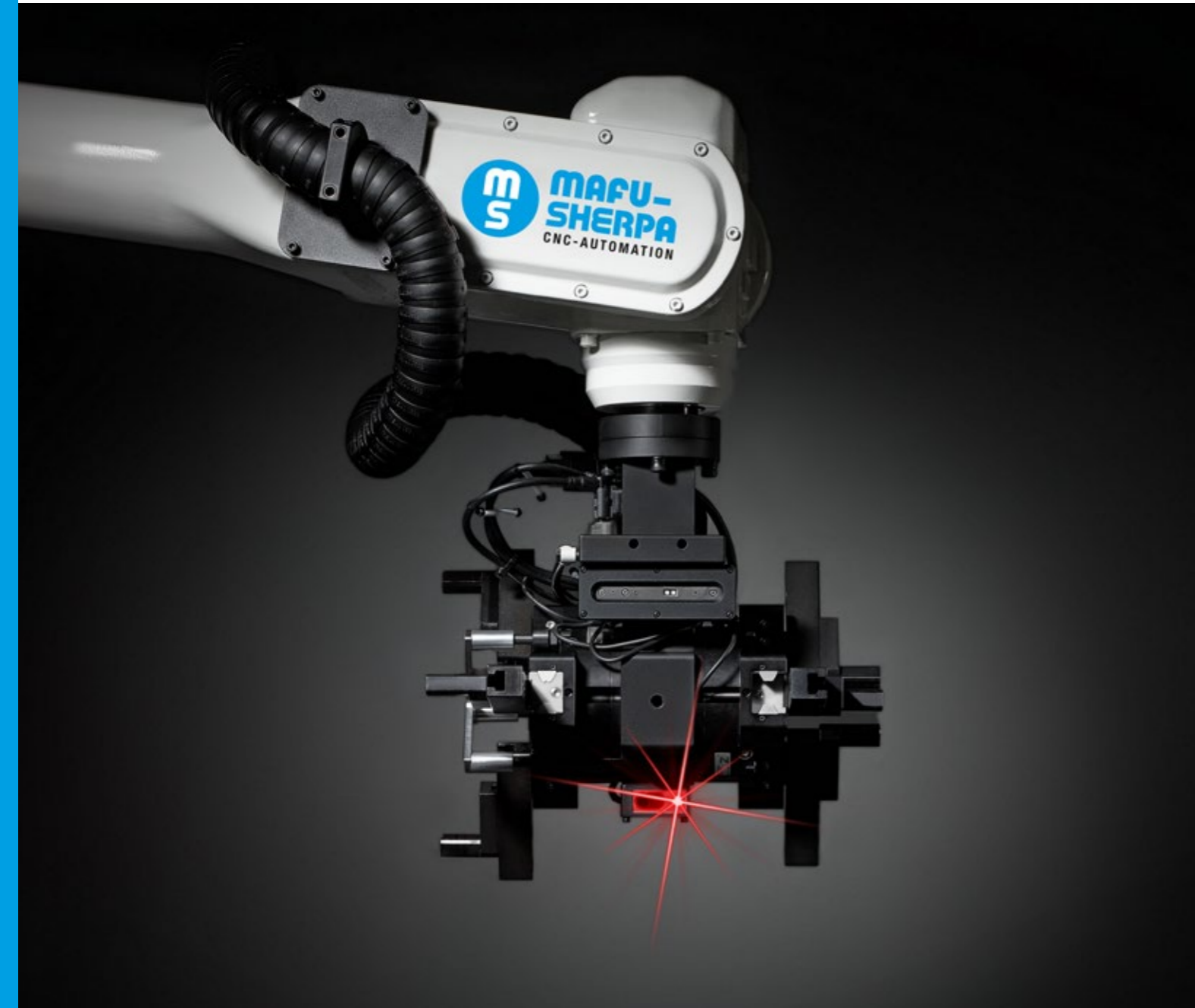
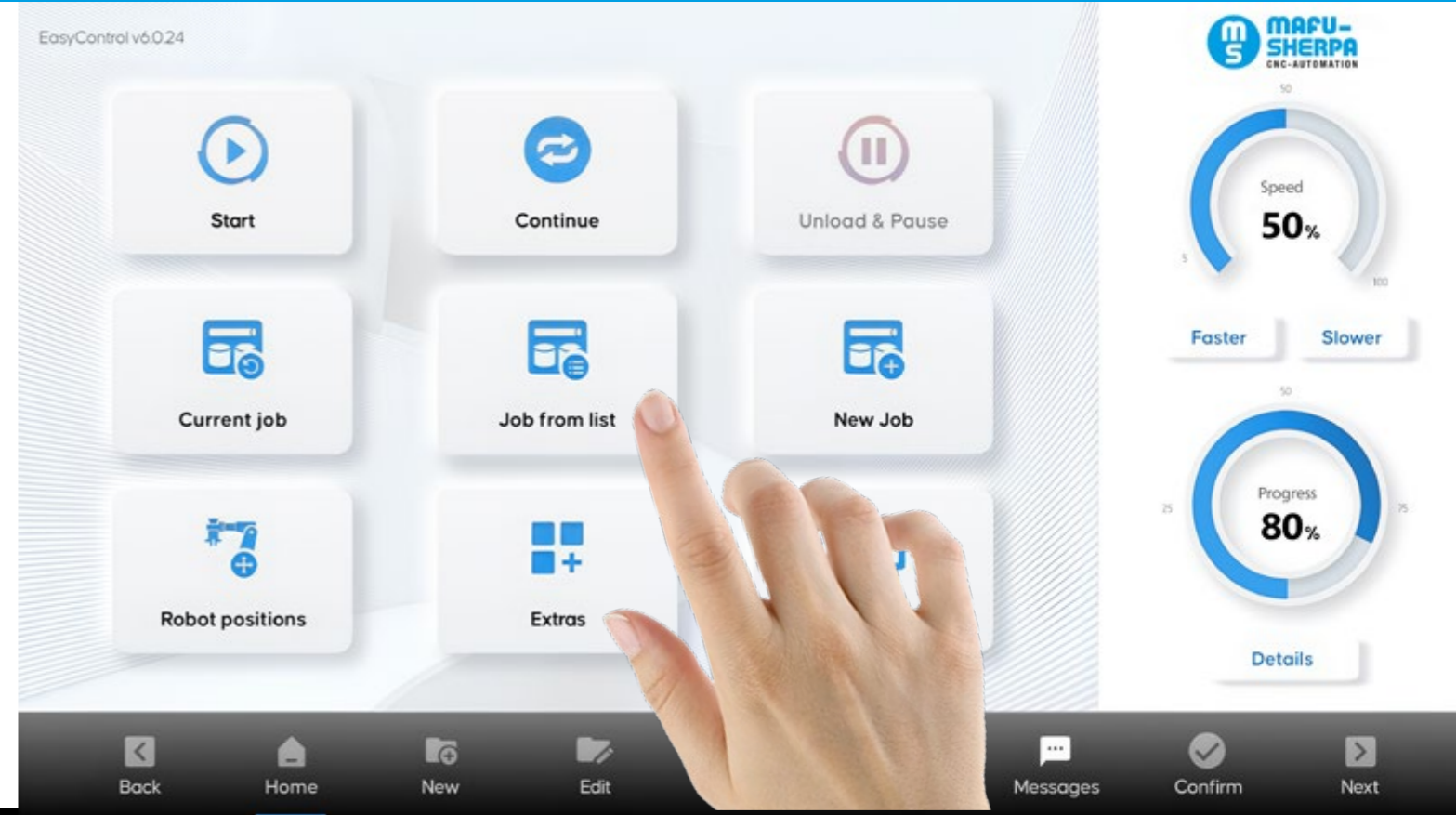

Intuitive

The robot cell is operated through a 17-inch touch display with a smartphone-like interface. Clear symbols and guided input screens simplify setup, so even new jobs can be configured without programming skills. Fast, user-friendly, and efficient – as easy as 1-2-3!

Flexible

When tomorrow's jobs are uncertain, flexibility matters. With batch sizes from 5 to 5,000, the SherpaLoader® delivers unmatched versatility. Its adaptable design fits any production environment, and its modular interface connects seamlessly with all major machining centers.



MS MAFU-SHERPA
CNC-AUTOMATION

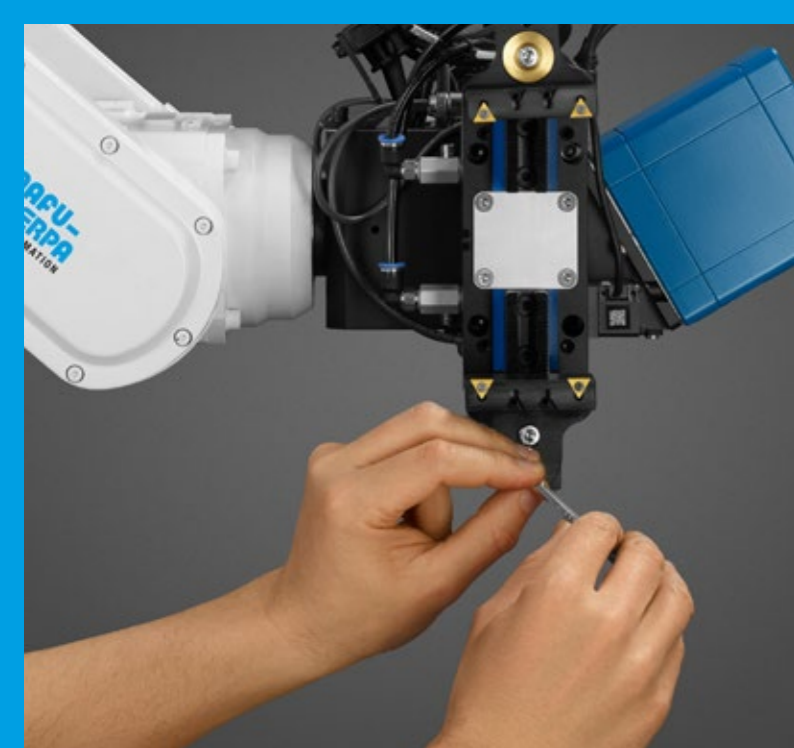

Adaptive Grippers

As a long-standing system partner, all robot cells are equipped with ZIMMER handling technology. Cylinders are clamped with 3-jaw centric grippers, while square material and shafts use 2-jaw parallel grippers. The gripper fingers are quickly and accurately adjusted over a wide range with fine-tooth gearing.

Electric Spindle Drive

Automating mechanical vises, the SherpaLoader® features an electric drive to clamp and release the vise. Torque and opening angle for releasing clamped parts are controlled with the touch display, and saved with each job. This allows even machining centers without pneumatic or hydraulic rotary unions to be automated.

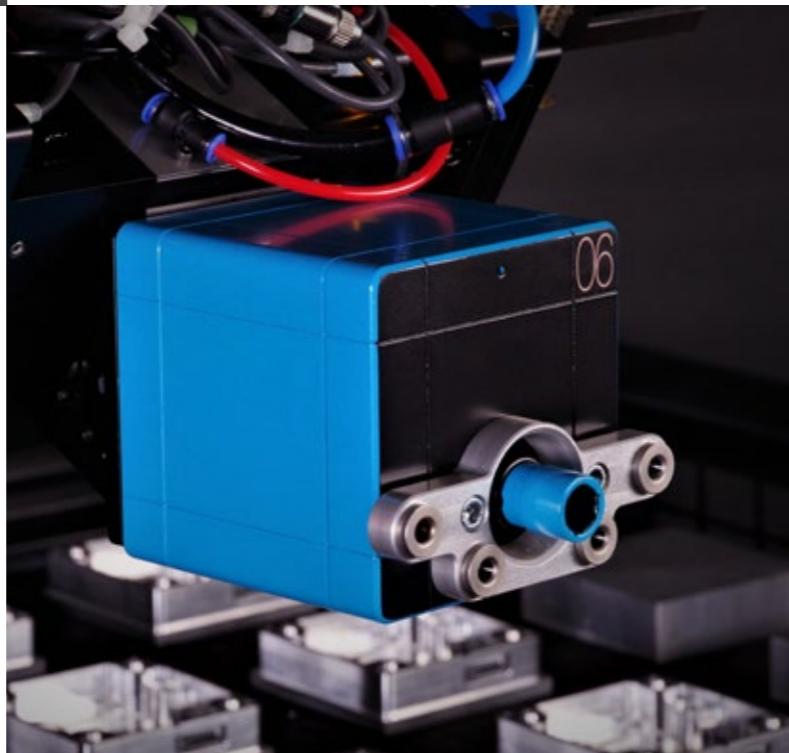

Air Blow

Cleanliness is key to precision work. The SherpaLoader® is equipped with an air nozzle to clean the clamping device of the machining center before loading blanks and to remove coolant and chips from parts after machining.





Universal Interface

The SherpaLoader® is compatible with both new and existing machines. For the past decade, machine tools have offered bus interfaces for automation. The SherpaLoader® supports popular standards like Profibus, Profinet, and EtherNet/IP. For machines without a bus interface, MAFU-SHERPA uses M-Functions and floating relay contacts. This helps customers to avoid costly retrofitting by the original machine manufacturer.



Safety Door Automation

For machining centers without powered safety doors, MAFU-SHERPA retrofits a maintenance-free electric door drive. This further reduces idle time in the machining process. Opening and closing speeds are individually adjustable, with automatic obstacle detection and secure speed and force limitation in compliance with EN ISO 13849-1, Performance Level d.

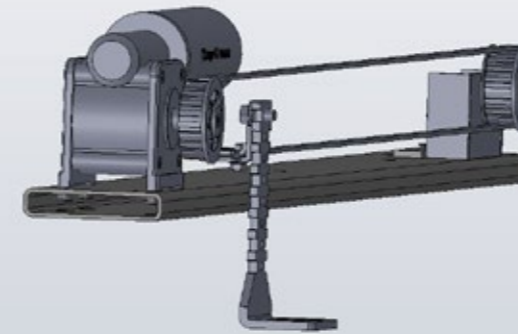

Remote Diagnostics

Every SherpaLoader® is equipped with an online diagnostics and remote maintenance interface. When needed, service technicians access machine logs, adjust the control system, and perform software updates remotely, ensuring fast troubleshooting and minimal downtime. Customers maintain full control over the interface, which connects securely to the maintenance server using TLS 1.2 and RSA 2048 asymmetric key exchange—the same security standard used in online banking.



15

Seconds*

That's all a SherpaLoader® needs for a loading cycle. While the CNC machine works on the next part, the robot unloads the finished piece and loads a new blank. Result: maximum effective spindle time.

5

Minutes*

That is the rapid changeover time only the SherpaLoader® delivers. Digitalized workflows replace complex staging mechanisms, with only the gripper fingers needing adjustment. While others retool, SherpaLoader® is already back in action.

12

Months*

An actively used SherpaLoader® pays for itself within a year. By eliminating costly mechanics and oversized components, it maximizes spindle time on high-value machines – at a fraction of the cost.

3000

Parts

Providing several days of unmanned production, the SherpaLoader® outperforms alternative systems. Its open layout, free from the constraints of rotary tables or lifting devices, offers up to 12 sqm of storage on the footprint of two Euro pallets—accommodating over 3,000 parts.

0

Magazines

Using a sophisticated vision system, the SherpaLoader® eliminates the need for magazines, pins, and grid plates. Blanks are placed on table trolleys, drawers, or pallets and they stay in place throughout the entire production process. This minimizes manual handling, enhances ergonomics, and reduces the overall workload for your team.

100 %

Service

Each SherpaLoader® is equipped with an online diagnostic interface, enabling remote diagnosis and maintenance of the control system. If on-site service is needed, SHERPA or a local service partner will quickly provide support.

** Estimate, may vary with the specific use case*

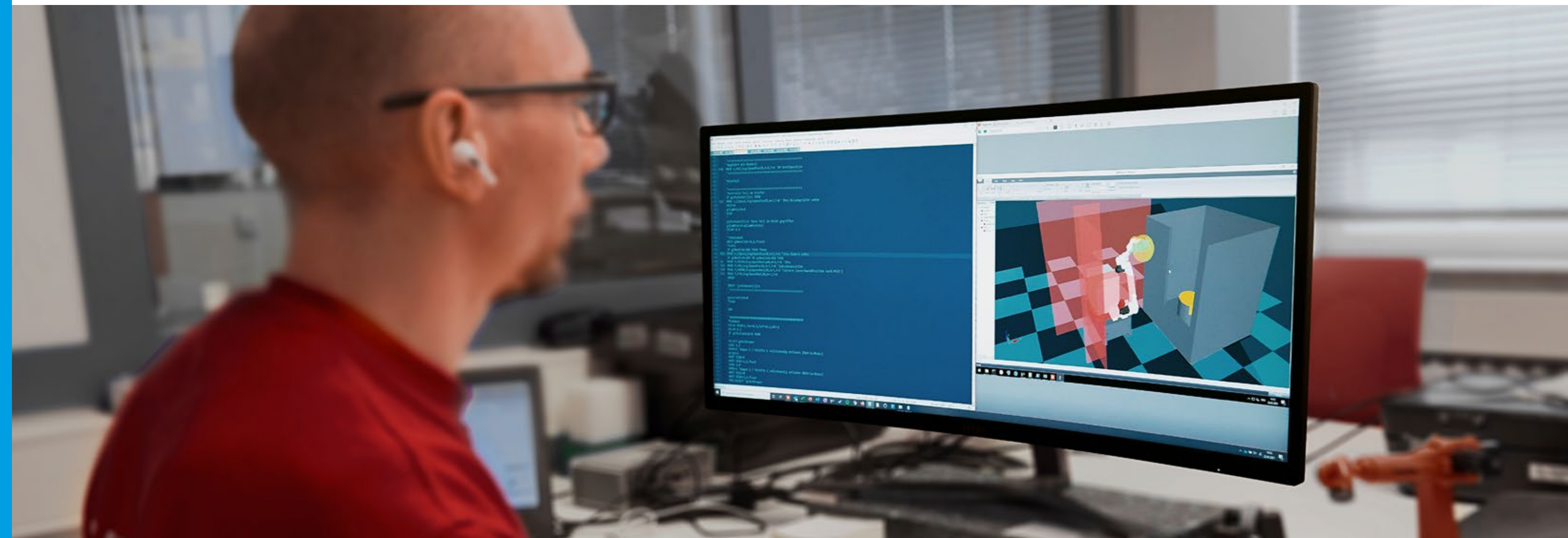

Technical Specifications

SherpaLoader®

	T7/M7	T12/M12	T25/M25	T50/M50	T88/M88	T225/M225
Workpieces						
Cylinders [mm]	Ø 10 - 150 l 10 - 150	Ø 10 - 150 l 10 - 150	Ø 15 - 220 l 10 - 200	Ø 20 - 300 l 10 - 300	Ø 20 - 300 l 10 - 300	project-specific project-specific
Cuboids [mm]	10 x 10 x 10 - 150 x 150 x 150	10 x 10 x 10 - 150 x 150 x 150	20 x 20 x 10 - 200 x 200 x 200	20 x 20 x 10 - 300 x 300 x 300	20 x 20 x 10 - 300 x 300 x 300	project-specific project-specific
Shafts [mm]	Ø 10 - 30 l 50 - 300	Ø 10 - 30 l 50 - 300	Ø 10 - 60 l 100 - 400	Ø 20 - 80 l 200 - 600	Ø 20 - 80 l 200 - 1000	project-specific project-specific
Weight [kg]	max. 4	max. 8	max. 18	max. 38	max. 73	max. 175
Workpiece Capacity						
Ø or length 40 mm	max. 164	max. 336	max. 2,880	max. 2,880	max. 2,880	project-specific
Ø or length 100 mm	max. 16	max. 72	max. 720	max. 720	max. 720	project-specific
Ø or length 200 mm	-	-	max. 160	max. 160	max. 160	project-specific
Storage Area						
Integrated [sqm]	0.4	2.1	-	-	-	-
Table trolley [sqm]	-	-	1.2	2.0	2.0	3.0
SpaceBox [sqm]	-	-	12.0	12.0	12.0	-
Pallet [sqm]	-	-	2.0	2.0	2.0	3.0
Supply						
Three-phase current	400V, 16A	400V, 16A	400V, 16A	400V, 16A	400V, 16A	400V, 16A
Compressed air [bar]	3 - 8	3 - 8	3 - 8	3 - 8	3 - 8	3 - 8
Dimensions						
Length [mm]	1,200	1,400	1,350	1,500	1,500	project-specific
Width [mm]	800	800	750	750	750	project-specific
Height [mm]	2,000	2,000	2,300	2,300	2,300	2,300
Weight [kg]	430	585	985	1,830	1,830	1,230

Specifications subject to change.



SUBSCRIBE

HOME

VIDEOS

PLAYLISTS

INFO



SherpaLoader® Compilation



MAZAK INTEGREX I-400ST



DMG DMU 65



MORI SEIKI NTX2000



GROB G350

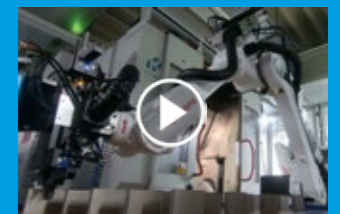

HERMLE C20U



OKUMA ST LU300-M



SPINNER U-1520

For more installation examples, follow us on
www.youtube.com/@mafusherpa

MAFU-SHERPA CNC AUTOMATION GMBH
DIESELSTR. 18
D-70736 FELLBACH
T. +49 711 2525 744 - 0
INFO@MAFU-SHERPA.COM
WWW.MAFU-SHERPA.COM

